

FULL MORTISE TEMPLATE BUTT HINGES

Sizes: 3½ × 3, 3½ × 3½, 3½ × 5 and 3½ × 6"

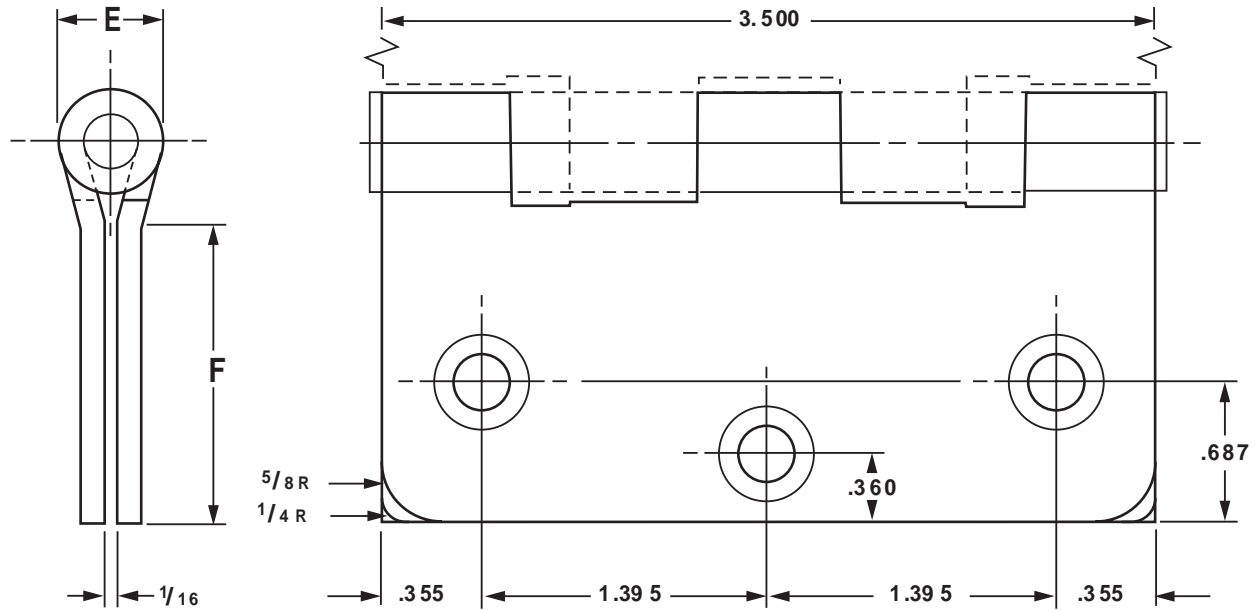

DO NOT SCALE

CLASS NUMBER		Gauge of Metal	(E) Outside Diameter	DISTANCE FROM EDGE OF LEAF TO SWAGE LINE (F)			
Steel Hinges	Nonferrous Hinges			3½ × 3	3½ × 3½	3½ × 5	3½ × 6
F179	F191	0.123	0.545	1 1/8	1 3/8	2 1/8	2 5/8
1900	1960	0.123	0.540	1 1/16	1 5/16	—	—
1900R	1960R	0.123	0.545	1 1/8	1 3/8	—	—
CB179	CB191	0.123	0.590	1 1/8	1 3/8	2 1/8	2 5/8
FBB179	FBB191	0.123	0.590	1 1/8	1 3/8	2 1/8	2 5/8
CB1900	CB1960	0.123	0.540	—	1 5/16	—	—
CB1900R	CB1960R	0.123	0.590	1 1/8	1 3/8	2 1/8	2 5/8

Template hinges of the hospital type conform to above screw hole location.
 Hospital type hinges are designated by prefix "HT" to class number.
 Also available "RD" radius corners (1 1/4 or 5/8)

Machine Screw Size — ½ × 10-24 F.H.
 Wood Screw Size — 1 × No. 10 F.H.

This template conforms with ANSI standard A156.7.